

DH1~DH2=20947 (±30)

Coordinates

記号	X	Y	R
GM	0	0	—
DH1	-10813	-2722	—
DH2	10022	-4886	—
a1	8364	8889	1200
a2	-8455	8802	1200
a3	-8078	-10529	2000
a4	-7303	-11081	2000
a5	8494	-10197	2000
a6	9203	-9562	2000

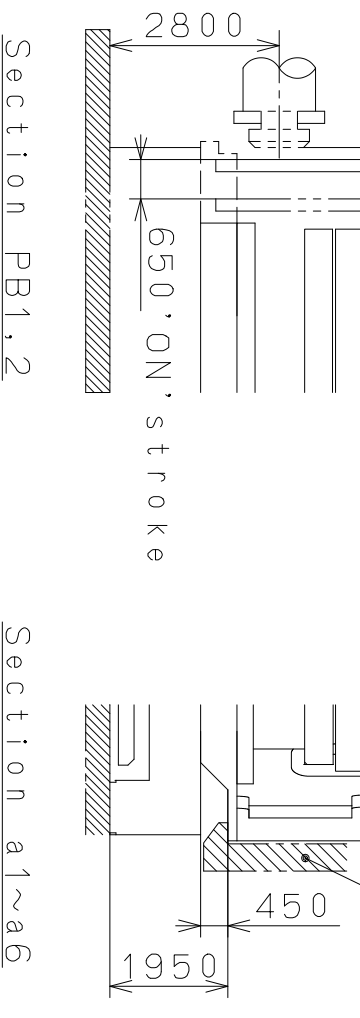
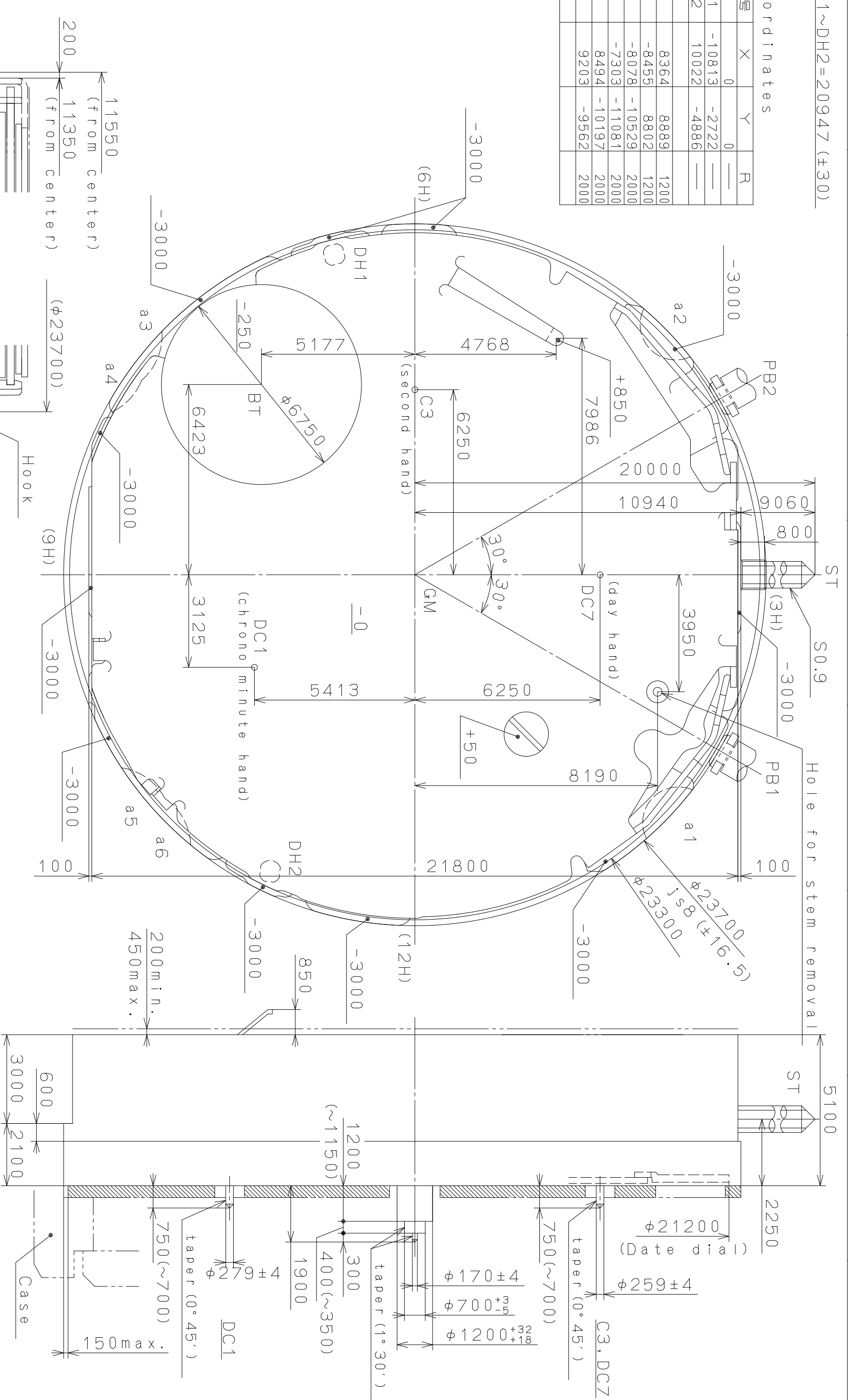

△	Quantity	Unit	Cal. NO.:
△	1	1/1000 mm	FS80
△	8	Scale	8 : 1
△		Date	
△		Drawn	
△		Checked	N. Suzuki
△		Approved	

Material: Alterations: Date: Description: Appr.:
 Heat Treatment: General Tolerances: N. Suzuki
 Hardness: Dimensions: Drawing No.: FS80C000
 Plating: Angles: CITIZEN WATCH CO., LTD. TOKYO, JAPAN

Frame for Case
 Drawing No.: FS80C000

Quantity: 1 / 1000 mm
 Unit: 8 : 1
 Scale: 8 : 1
 Date:
 Drawn:
 Checked: N. Suzuki
 Approved:
 Name: Frame for Case
 Drawing No.: FS80C000

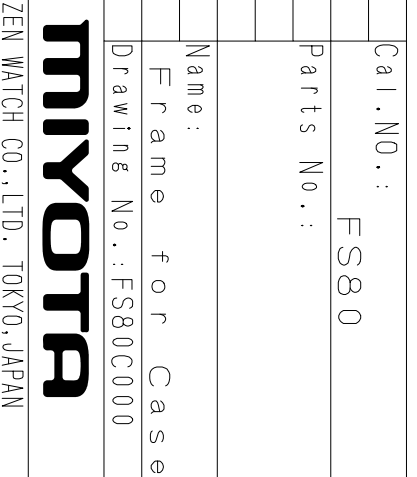

Case
 DC1
 taper ($0^\circ 45'$)
 taper ($1^\circ 30'$)
 taper ($0^\circ 45'$)

MIYOTA
 CITIZEN WATCH CO., LTD. TOKYO, JAPAN

confidential papers 2013/03/25 (10:27:33)

This drawing is provisional and subject to our reconfirmation and/or revision without notice.

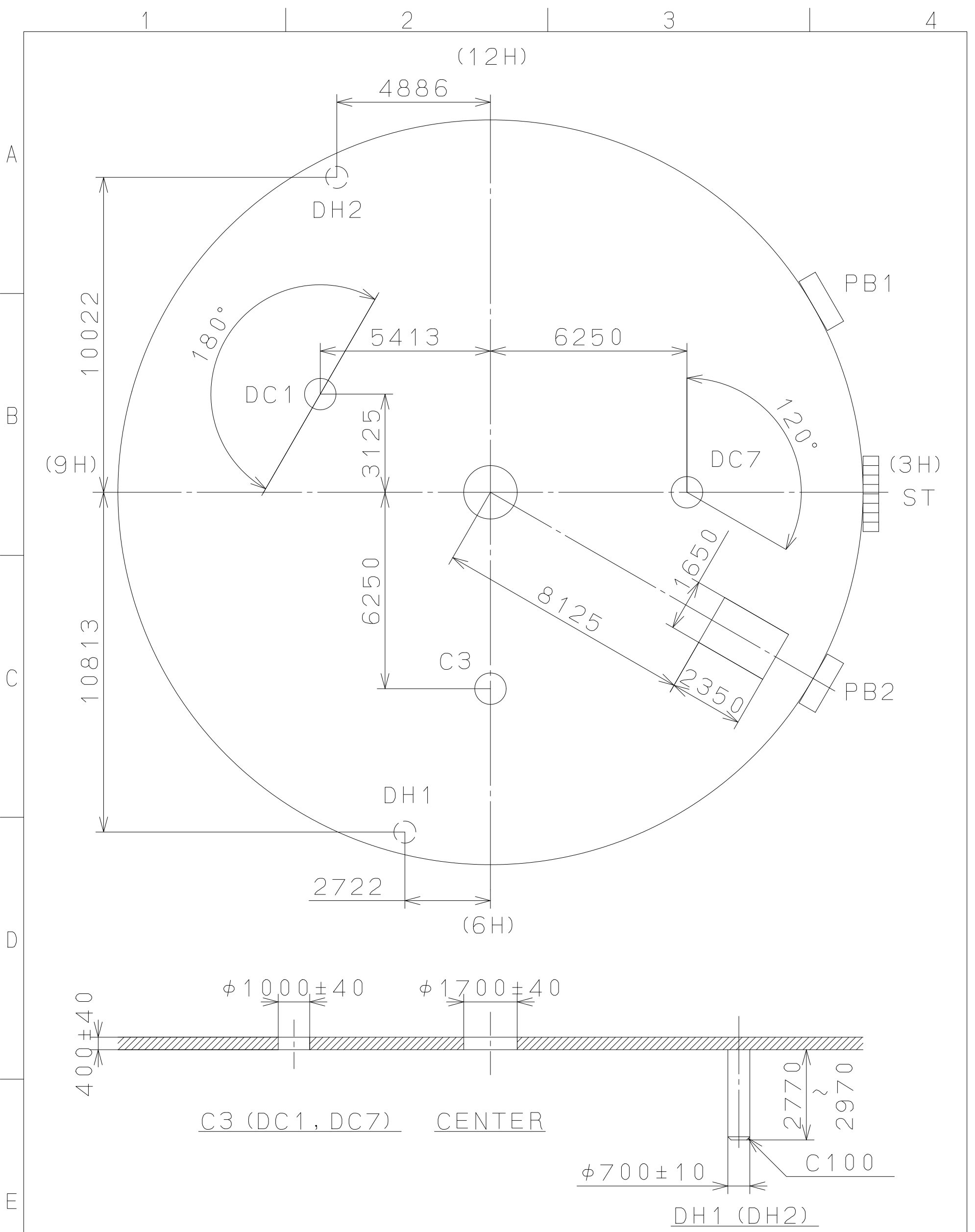

⑤			Quantity		Cal.NO.:
④			Unit	1/1000mm	FS80-00A
③			Scale	6:1	Parts No.:
②			Date		
①			Drawn		
Mark	Date	Description	Appro.	Checked	Name:
		Alterations		Approved	Indications for Dial
Material					Drawing No.: FS80D000
Heat Treatment				General Tolerances	MIYOTA CITIZEN WATCH CO., LTD. TOKYO, JAPAN
Hardness				Dimensions	
Plating				Angles	

This drawing is provisional and subject to our reconfirmation and/or revision without notice.

*** T I P W 065-549 (01) *** (2100 1121) 01-12-07

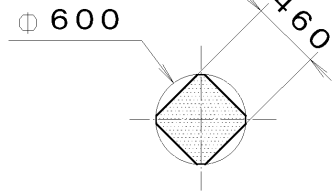

Section A-A

S0. 9, P=0. 225mm

⌀ 1000

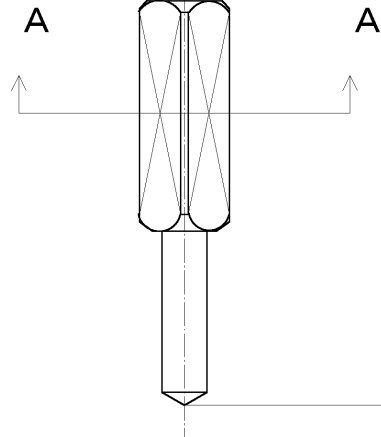

7			Quantity		Cal. No. :
6			Unit	1/1000 mm	
5			Scale	20:1	Parts:
4			Date		065-549
3			Drawn		Name:
2			Checked	T. Hiruta	SETTING STEM
1			Approved		Drawing No. : 5490S000
Material					
Heat Treatment		General Tolerances			
Hardness		Dimensions			
Plating		Angles			

CITIZEN WATCH CO., LTD.
TOKYO, JAPAN